



Massskizze

Bei Fragen und Anregungen stehen wir Ihnen gerne zur Seite:

Faserplast AG

Sonnmattstrasse 6-8
9532 Rickenbach TG

Tel. 071 929 29 29
Mail: info@faserplast.ch
www.faserplast.ch

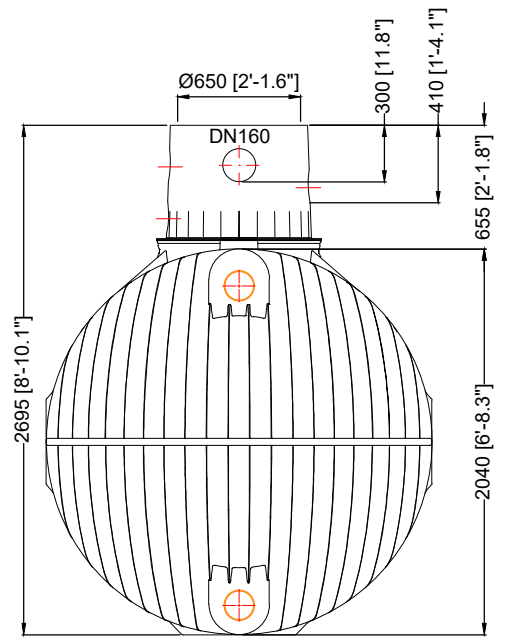
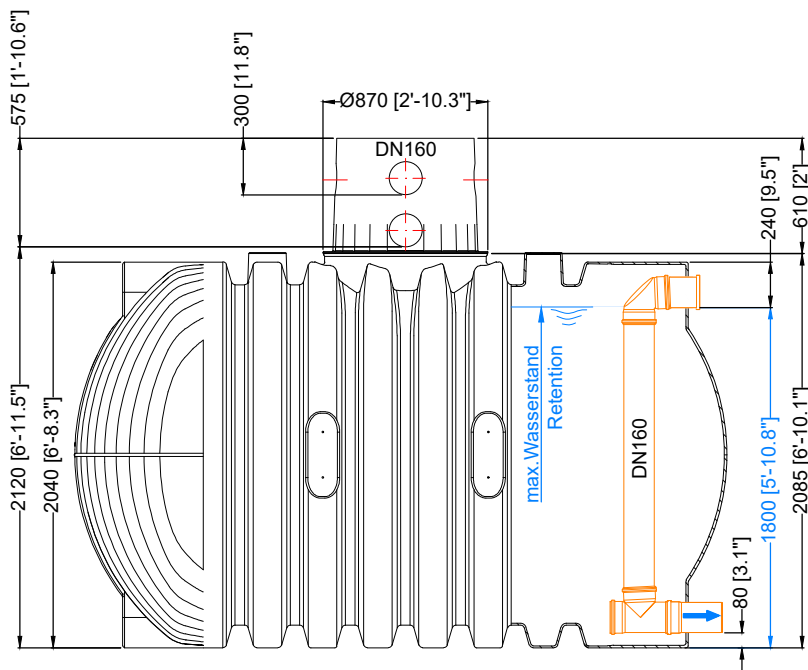
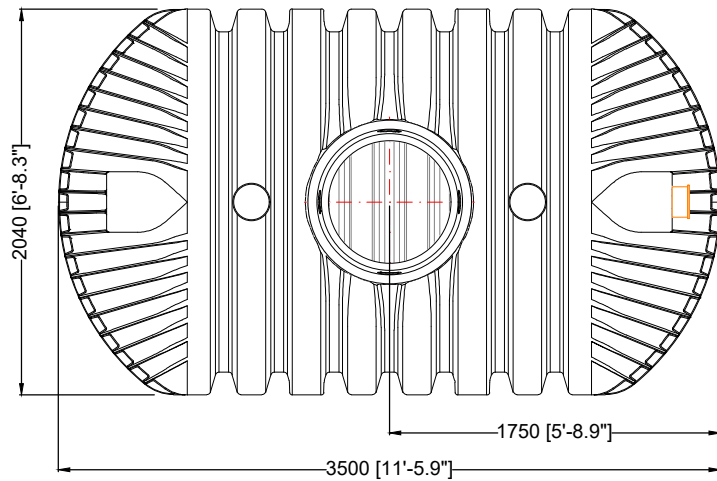

D		GRAF Carat XL Retentionszisterne 8500 L / 2245 gal.		Artikel-Nr. product no.	370504
				article no.	(370043/ 371018)
GB	GRAF Carat XL detention 8500 L / 2245 gal.	ES	GRAF Sistema de retención Carat XL tanque 8500 L / 2245 gal.	FR	GRAF Cuve de rétention Carat XL 8500 L / 2245 gal.
				revision	
gezeichnet drawn	EMU	Gewicht weight	380 kg	Otto Graf GmbH Carl-Zeiss-Str. 2-6 DE-79331 Teningen mail@graf.info www.graf.info	
Datum date	2020.01.15	Toleranz tolerance	+/- 3%		
Maßstab scale	M 1:40	Einheiten units	mm [inch] gal. = US gal.		
				